



— Pharma Process & Packaging

www.saintyco.com

Ultra-8

Automatic Gummy Bagger



A Bagger to Count Gummies Into Pre-made Gusseted, Resealable Bags

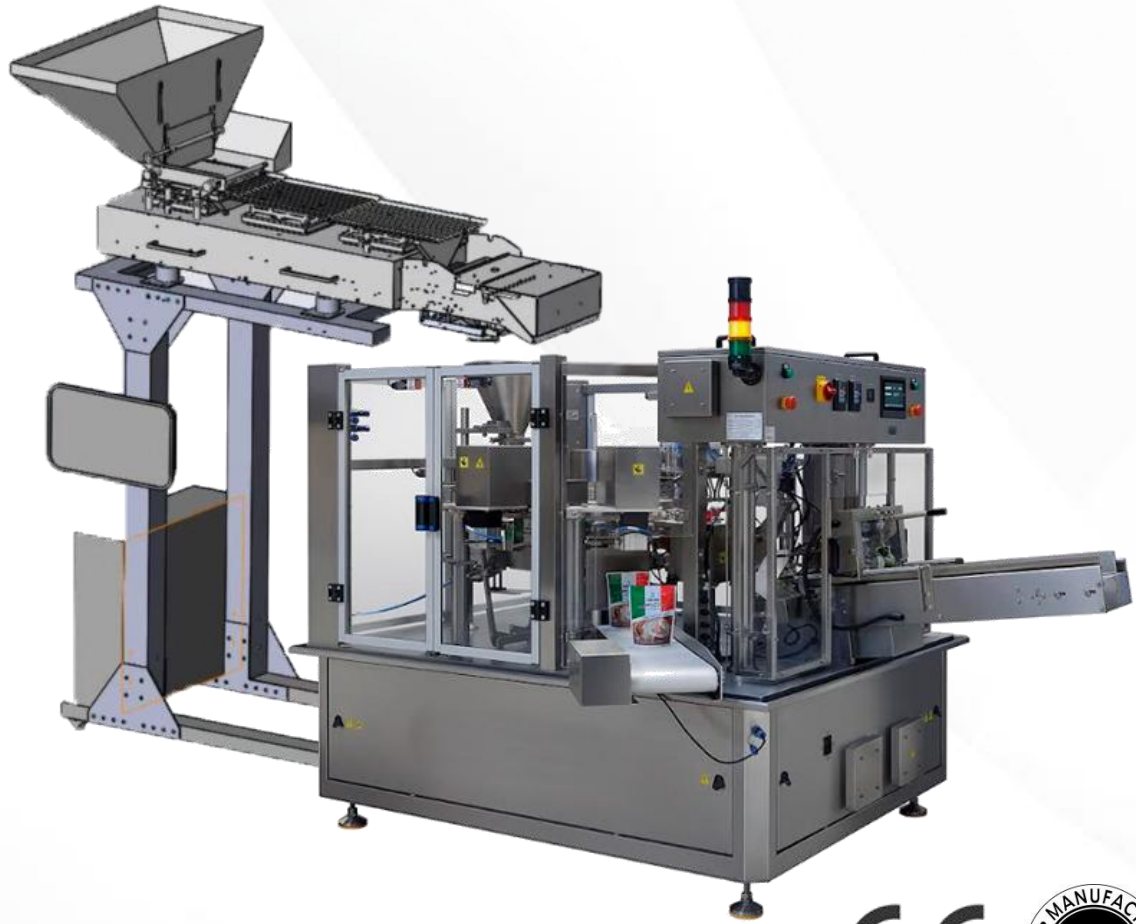

Ultra-8 Rotary Fill and Seal Premade Pouch Bag

Rotary Automatic fill and Seal packing machine for Premade Pouch or Doypack. Easy to connect to any dosing for filling device for Liquids, Powders, Solid or Granulated Products. 8 Working Stations Rotary machine Speed up to 35 ppm.





“We're Different,
We've Always Been
Different!”

NUMBER of STATIONS: 8

STATION 1

Pouch Magazine & Auto Loading Station

- Pick Up Arm with Suction Pad
- Pouch Width Adjustment Guide
- Pouch Transfer Jaw
- Toolless Size Change-overs
- Holds up to 1,000 bags

STATION 2 Zipper Opening Station

STATION 3 Date Coding (option)

- Inkjet or Emboss

STATION 4

Pouch Mouth & Bottom Gusset Opening

- 8 Pouch Grippers
- Motorized Gripper Adjustment via Touch Screen

STATION 5 Fill Station / Counter

- 12 Track Electronic Channel Counting System
- 304 Stainless Contact Parts

Filling Material:

- Gummies, Capsules, Tablets, Softgels, Candies
- Diving Fill Funnel
- 29mm Guide Tube Openings
- Dust Proof Counting

Counting Rate:

- Max. 6,000 Pieces Per Minute
(depending upon size, shape & surface tension)
- 20 Liter Product Hopper

Fill Rate:

35 Pouches Per Minute Maximum

Dimensions:

W 526 x D 1,270 x H 920mm

STATION 6 Sealing & Air Removal

- Air Squeeze Removal
- Sealing Jaw
- Bar Sealing System
- 0 300 C Temperature Range
- PID Temperature Control System

STATION 7 Cooling Jaws

STATION 8 Discharge

- Pouch Discharge Conveyor

Options:

- ✓ Inkjet Printer Markem / Image
- ✓ Bulk Elevator Feeder
- ✓ Dimpled Trays for Gummy Products

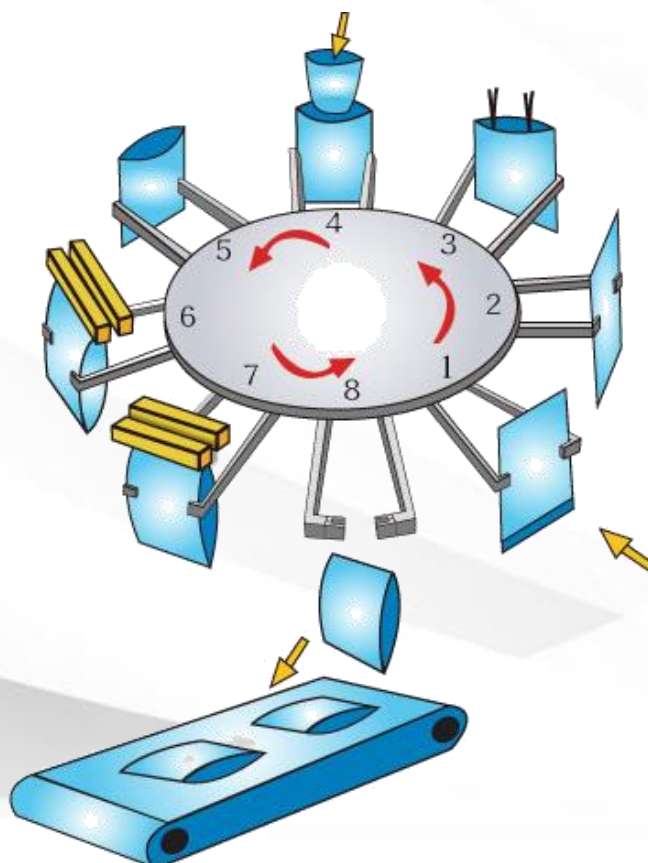

Features:

- Simple integration of filler, such as Multi-Head Weigher, Auger Filler, Volumetric Cup Doser, Liquid & Paste Pump, and other peripheral equipment.
- Contact parts made of SS316L
- Panasonic PLC and 7"Color HMI.
- Indexing gear box for accuracy and stable position.
- Speed adjusted thru frequency inverter.
- Quick format change Operating and adjusting via TOUCH SCREEN.
- Fault indication on the TOUCH SCREEN
- Alarm with sound and three color lamp when error occur,such as no product to fill.
- #304 Stainless Steel Construction Easy maintenance.Washdown design.
- Omron PI.D. temperature controller.
- GMP compliant
- CE Certificate



Technical Data	Ultra-8
Pouch length	150 - 330mm
Pouch Width	100-220mm
Speed	30-60 pouches/min(The speed depend on the products status and filling volume)
Pouch materials	Heat sealable laminated film
Pouch type	Flat pouch, Standup pouch,Zipper pouch, Gusset pouch and Corner spout pouch,(by different optional parts).
Power supply	220/380V 50/60Hz,3pH, 4KW
Air consumption	0.6-0.7 Mpa
Weight	1300 kgs
Dimension	2680×1860×1675 mm

GummyCount-40 Features:

- Stainless steel 316L with contact part, 304 for other part.
- Panasonic PLC & Touch Screen Control Panel
- Three-stage vibration
- Product memory
- Error message display
- Head height adjustment
- Variable speed
- Accurate counting target speed
- Transparent soft capsule counting
- Dismantling without the use of tools
- No pouch, no fill
- Sensor control counting accuracy
- Level sensor in Hopper

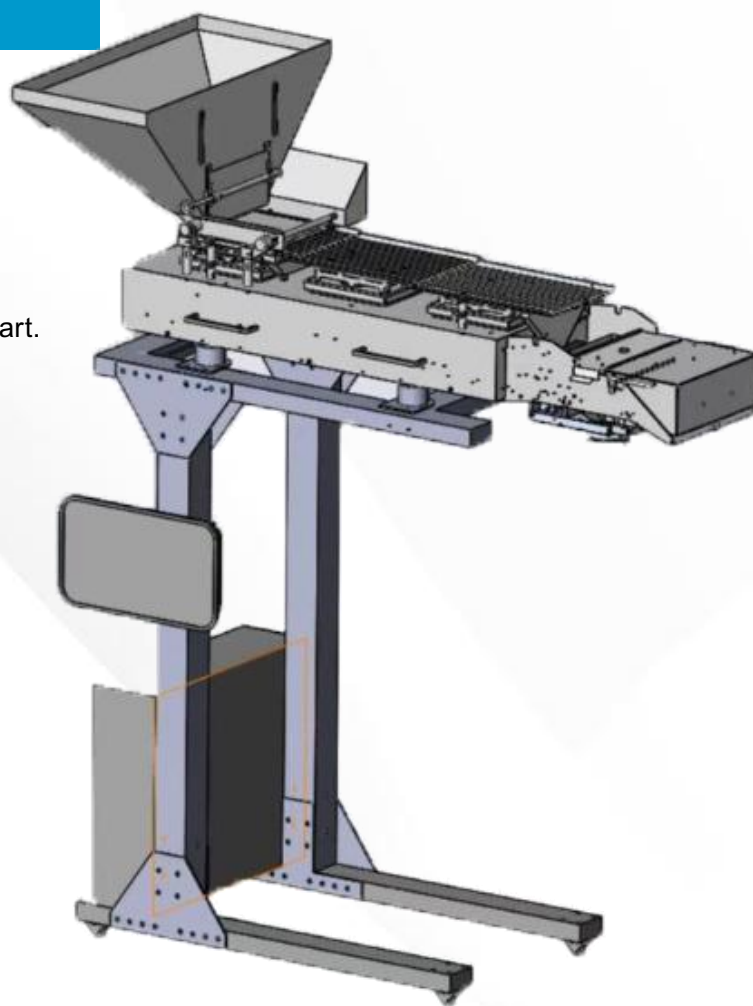

Technical Data	GummyCount-40
Number of Counting Channels	10 or 12
Production Output	40-50pouches/min
Product Specification	Gummy Diameter 2 ~ 25mm
Capacity	5,000-6,000pcs/m
Container height	25-75mm
Feeding hopper	38L
Dosing	Single outlet
Configuration	Single 12 track linear
Conveyor	1450 mm single lane slat conveyor
Variable speed	Electronic inverter control
Pressure of compressed air	0.4-0.6Mpa
Air consumption	120L/min
Support	Heavy duty wind down castors
Power supply	220/380V 50/60Hz 1pH
Power	2kw

SaintyCo Also Offer:

- Gummy Counting Bottle Packing Solution
- Automatic Weighing Bottling Production Line
- Sugar sanding drum
- Gummy Coating Pan
- Gummy Molds
- Pouch Packaging Machine

For additional information, please drop E-mail to info@saintyco.com

